

RV-10.14.50-PP 208021

Primary Usage

Reference No.

Sign. and date

Copy inv. No.

Repl. Inv. No.

Sign. and date

Orig. Inv. No.

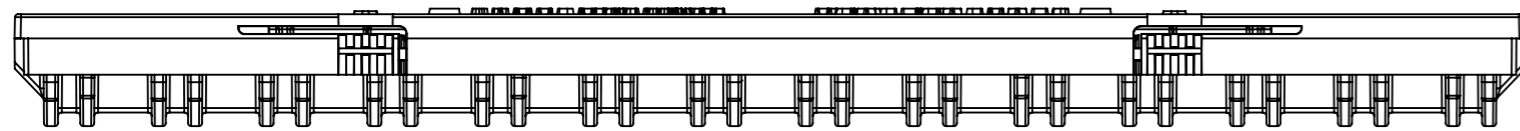
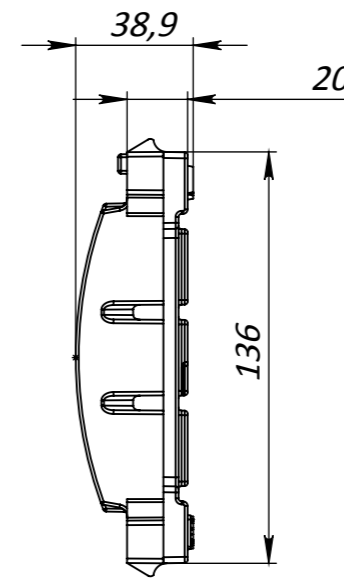
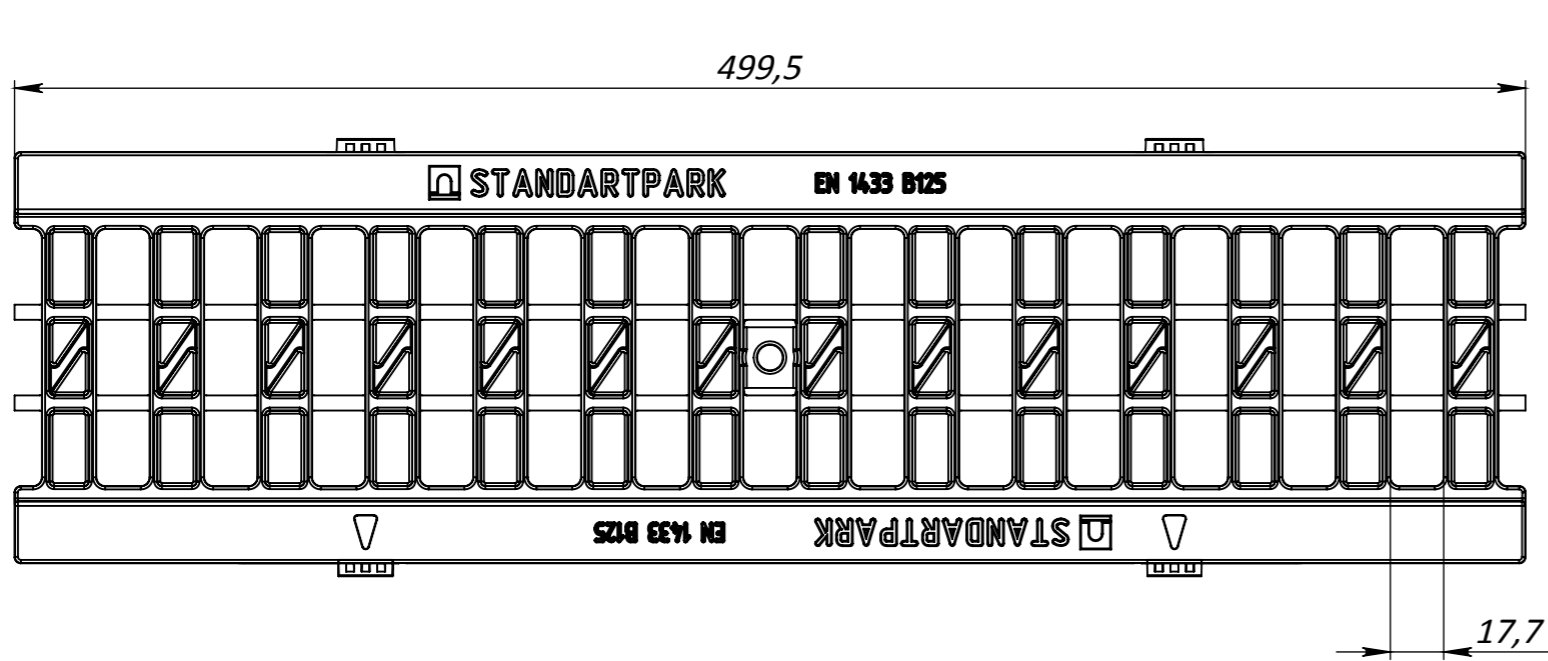

1. Area of water intake slots 180 sq cm
2. Deviation of the actual weight of the nominal can be up to 10%

					Art.	208021				
					RV-10.14.50-PP 208021					
					Plastic Grating Mesh			Let.	Weight	Scale
					Load Class B				1.2	1:2.5
					Plastic			Sheet	Sheets 1	
								